

Centre Scientifique et
Technique du Bâtiment

84 avenue Jean Jaurès
Champs sur Marne
F-77447 Marne-la-Vallée Cedex 2
Tél. : (33) 01 64 68 82 82
Fax : (33) 01 60 05 70 37

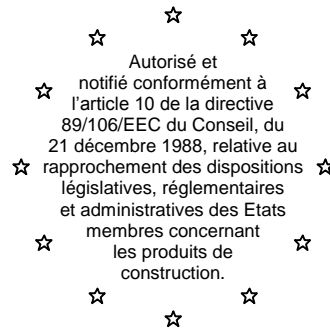

MEMBRE DE L'EOTA

European Technical Approval

ETA-08/0201

(English language translation, the original version is in French language)

Nom commercial :

Trade name:

SPIT EPOBAR / EPOMAX

Titulaire :

Holder of approval:

Société SPIT

Route de Lyon

BP 104

F 26501 BOURG-Lès-VALENCE

France

Type générique et utilisation prévue du produit de construction :

Generic type and use of construction product:

Scellement d'armatures rapportées, diamètres 8 à 32mm, à l'aide la résine SPIT EPOBAR / **EPOMAX**

Post installed rebar connections diameter 8 to 32 mm made with SPIT EPOBAR / EPOMAX injection mortar.

Validité du :

au :

Validity from / to:

04/02/2011

23/07/2013

Usine de fabrication :

Manufacturing plant:

Société SPIT

Route de Lyon

F-26501 BOURG-LES-VALENCE

France

Le présent Agrément technique européen contient :

This European Technical Approval contains:

23 pages incluant 13 annexes faisant partie intégrante du document.

23 pages including 13 annexes which form an integral part of the document.

This European Technical Approval cancels and replaces ETA-08/0201 with validity from 23/07/2008 to 23/07/2013.

Cet Agrément Technique Européen annule et remplace l'ETA-08/0201 valide du 23/07/2008 au 23/07/2013



Organisation pour l'Agrément Technique Européen
European Organisation for Technical Approvals

I LEGAL BASES AND GENERAL CONDITIONS

1. This European Technical Approval is issued by the Centre Scientifique et Technique du Bâtiment in accordance with:

- Council Directive 89/106/EEC of 21 December 1988 on the approximation of laws, regulations and administrative provisions of Member States relating to construction products¹, modified by the Council Directive 93/68/EEC of 22 July 1993²;
- Décret n° 92-647 du 8 juillet 1992³ concernant l'aptitude à l'usage des produits de construction;
- Common Procedural Rules for Requesting, Preparing and the Granting of European Technical Approvals set out in the Annex of Commission Decision 94/23/EC⁴;
- Guideline for European Technical Approval of « Metal Anchors for use in Concrete » ETAG 001, edition 1997, Part 1 « Anchors in general », Part 5 « Bonded anchors» and Technical Report for Post Installed Rebar Connections TR23.

2. The Centre Scientifique et Technique du Bâtiment is authorised to check whether the provisions of this European Technical Approval are met. Checking may take place in the manufacturing plant (for example concerning the fulfilment of assumptions made in this European Technical Approval with regard to manufacturing). Nevertheless, the responsibility for the conformity of the products with the European Technical Approval and for their fitness for the intended use remains with the holder of the European Technical Approval.

3. This European Technical Approval is not to be transferred to manufacturers or agents of manufacturer other than those indicated on page 1; or manufacturing plants other than those indicated on page 1 of this European Technical Approval.

4. This European Technical Approval may be withdrawn by the Centre Scientifique et Technique du Bâtiment pursuant to Article 5 (1) of the Council Directive 89/106/EEC.

5. Reproduction of this European Technical Approval including transmission by electronic means shall be in full. However, partial reproduction can be made with the written consent of the Centre Scientifique et Technique du Bâtiment. In this case partial reproduction has to be designated as such. Texts and drawings of advertising brochures shall not contradict or misuse the European Technical Approval.

6. The European Technical Approval is issued by the approval body in its official language. This version corresponds to the version circulated within EOTA. Translations into other languages have to be designated as such.

1 Official Journal of the European Communities n° L 40, 11.2.1989, p. 12

2 Official Journal of the European Communities n° L 220, 30.8.1993, p. 1

3 Journal officiel de la République française du 14 juillet 1992

4 Official Journal of the European Communities n° L 17, 20.1.1994, p. 34

II SPECIFIC CONDITIONS OF THE EUROPEAN TECHNICAL APPROVAL

1 Definition of product and intended use

1.1. Definition of product

The SPIT EPOBAR / EPOMAX is used for the connection, by anchoring or overlap joint, of reinforcing bars (rebars) in existing structures made of ordinary non-carbonated concrete C12/15 to C50/60. The design of the post-installed rebar connections is done in accordance with EN 1992-1-1 October 2005 (EN 1992-1-1).

Covered are rebar anchoring systems consisting of SPIT EPOBAR / EPOMAX bonding material and an embedded straight deformed reinforcing bar diameter, d , from 8 to 32 mm with properties according to Annex C of EN 1992-1-1 and EN 10080. The classes B and C of the rebar are recommended.

1.2. Intended use

The ETA covers applications in non-carbonated concrete C 12/15 to C 50/60 (EN 206-1) only, which are also allowed with straight deformed cast-in bars according to EN 1992-1-1, e.g. those in the following applications:

- an overlapping joint with existing reinforcement in a building component, see Figure 1 and 2 in annex 4.
- anchoring of the reinforcement at a slab or beam support; end support/bearing of a slab designed as simply supported as well as its reinforcement for restraint forces, see Figure 3 in annex 4.
- anchoring of reinforcement of building components stressed primarily in compression, see Figure 4 in annex 4.
- anchoring of reinforcement to cover the line of acting tensile force, see Figure 5 in annex 4.

The SPIT EPOBAR / EPOMAX anchoring systems can be used with the following limitations:

- ✓ The rebars can be placed in holes made with hammer drilling technique or diamond drilling technique.
- ✓ The rebars may be used in the following temperature range : -40°C to $+80^{\circ}\text{C}$ (max short term temperature $+80^{\circ}\text{C}$ and max long term temperature $+50^{\circ}\text{C}$)
- ✓ According to EN 206-1 the allowable chloride content in concrete is limited to 0.40 % (Cl 0,40) related to cement content.
- ✓ The rebars may be installed in dry or wet concrete; it must not be in flooded holes.
- ✓ The rebar connections may be used for predominantly static loads

The fire resistance of post-installed rebar connections is not covered by this ETA.

Fatigue, dynamic or seismic loading of post-installed rebar connections are not covered by this ETA.

The provisions made in this European Technical Approval are based on an assumed intended working life of the rebar connections of 50 years. The indications given on the working life cannot be interpreted as a guarantee given by the producer, but are to be regarded only as a means for

choosing the right products in relation to the expected economically reasonable working life of the works.

2 Characteristics of product and methods of verification

2.1. Characteristics of product

The SPIT EPOBAR / EPOMAX injection adhesive corresponds to the drawings and provisions given in annexes 1 to 3.

The SPIT EPOBAR / EPOMAX injection adhesive described in annex 1 to 3 is a two components system. The two components of the injection mortar are delivered in unmixed condition in cartridges of sizes ranging from 345ml to 825ml. Each cartridge is marked with the identifying mark "SPIT EPOBAR" or "SPIT EPOMAX" with the charge code and the storage life.

2.2. Methods of verification

The assessment of fitness of the rebar connection for the intended use in relation to the requirements for mechanical resistance and stability and safety in use in the sense of the Essential Requirements 1 and 4 has been made in accordance with the « Guideline for European Technical Approval of Metal Anchors for use in Concrete », Part 1 « Anchors in general », Part 5 « Bonded anchors » and Technical Report n° 023 "Assessment of post installed rebar connections".

In addition to the specific clauses relating to dangerous substances contained in this European Technical Approval, there may be other requirements applicable to the products falling within its scope (e.g. transposed European legislation and national laws, regulations and administrative provisions). In order to meet the provisions of the UE Construction Products Directive, these requirements need also to be complied with, when and where they apply.

3 Evaluation of Conformity and CE marking

3.1. Attestation of conformity system

The system of attestation of conformity 2 (i) (referred to as system 1) according to Council Directive 89/106/EEC Annex III laid down by the European Commission provides:

a) tasks for the manufacturer:

1. factory production control,
2. further testing of samples taken at the factory by the manufacturer in accordance with a prescribed test plan.

b) tasks for the approved body:

3. initial type-testing of the product,
4. initial inspection of factory and of factory production control,
5. continuous surveillance, assessment and approval of factory production control.

3.2. Responsibilities

3.2.1. Tasks of the manufacturer, factory production control

The manufacturer has a factory production control system in the plant and exercises permanent internal control of production. All the elements, requirements and provisions adopted by the manufacturer are documented in a systematic manner in the form of written policies and procedures. This production control system ensures that the product is in conformity with the European Technical Approval.

The manufacturer shall only use raw materials supplied with the relevant inspection documents as laid down in the prescribed test plan⁵. The incoming raw materials shall be subject to controls and tests by the manufacturer before acceptance. Check of incoming materials shall include control of the inspection documents presented by suppliers.

The frequency of controls and tests conducted during production is laid down in the prescribed test plan taking account of the automated manufacturing process of the product.

The results of factory production control are recorded and evaluated. The records include at least the following information:

- designation of the product, basic material and components;
- type of control or testing;
- date of manufacture of the product and date of testing of the product or basic material and components;
- result of control and testing and, if appropriate, comparison with requirements;
- signature of person responsible for factory production control.

The records shall be presented to the inspection body during the continuous surveillance. On request, they shall be presented to the Centre Scientifique et Technique du Bâtiment.

Details of the extent, nature and frequency of testing and controls to be performed within the factory production control shall correspond to the prescribed test plan which is part of the technical documentation of this European Technical Approval.

3.2.2. Tasks of approved bodies

3.2.2.1. Initial type-testing of the product

For initial type-testing the results of the tests performed as part of the assessment for the European Technical Approval shall be used unless there are changes in the production line or plant. In such cases the necessary initial type-testing has to be agreed between the Centre Scientifique et Technique du Bâtiment and the approved bodies involved.

⁵ The prescribed test plan has been deposited at the Centre Scientifique et Technique du Bâtiment and is only made available to the approved bodies involved in the conformity attestation procedure.

3.2.2.2. Initial inspection of factory and of factory production control

The approved body shall ascertain that, in accordance with the prescribed test plan, the factory and the factory production control are suitable to ensure continuous and orderly manufacturing of the anchor according to the specifications mentioned in 2.1. as well as to the Annexes to the European Technical Approval.

3.2.2.3. Continuous surveillance

The approved body shall visit the factory at least once a year for regular inspection. It has to be verified that the system of factory production control and the specified automated manufacturing process are maintained taking account of the prescribed test plan.

Continuous surveillance and assessment of factory production control have to be performed according to the prescribed test plan.

The results of product certification and continuous surveillance shall be made available on demand by the certification body or inspection body, respectively, to the Centre Scientifique et Technique du Bâtiment. In cases where the provisions of the European Technical Approval and the prescribed test plan are no longer fulfilled the conformity certificate shall be withdrawn.

3.3. CE-Marking

The CE marking shall be affixed on each packaging of anchors. The symbol « CE » shall be accompanied by the following information:

- name or identifying mark of the producer and manufacturing plant;
- the last two digits of the year in which the CE-marking was affixed;
- number of the EC certificate of conformity;
- number of the European Technical Approval;

4 Assumptions under which the fitness of the product for the intended use was favourably assessed

4.1. Manufacturing

The resin is manufactured in accordance with the provisions of the European Technical Approval using the automated manufacturing process as identified during inspection of the plant by the Centre Scientifique et Technique du Bâtiment and the approved body and laid down in the technical documentation. Changes to the product or production process, which could result in this deposited data/information being incorrect, should be notified to the Centre Scientifique et Technique du Bâtiment before the changes are introduced. The Centre Scientifique et Technique du Bâtiment will decide whether or not such changes affect the approval and consequently the validity of the CE marking on the basis of the approval and if so whether further assessment or alterations to the approval shall be necessary.

4.2. Drafting

Rebar connection must be designed in keeping with good engineering practice. Allowing for the loads to be anchored, design calculations and design drawings must be produced which can be checked. At least the following must be given in the design drawings:

- Concrete strength.
- Diameter, drilling technique, concrete cover, spacing and anchorage depth of the rebars.
- Dimension for the depth of adhesive (dispensing amount to be marked on the mixer extension as per annex 9,
- Kind of preparation of the joint between building component being connected.

4.3. Rebar connection design as per EN 1992-1-1

4.3.1. General points

The actual position of the reinforcement in the existing building component must be determined on the basis of the construction documentation and allowed for when drafting.

The transfer of internal section forces in the joint must be verified in accordance to EN 1992-1-1 when a new building component is being connected. The transfer of shear forces between new and old concrete shall be designed according to EN 1992-1-1. The joints for concreting must be roughened to at least such an extent that aggregate protrude.

The design of rebar connections and determination of the internal section forces to be transferred in the construction joint shall be in keeping with the EN 1992-1-1.

Verification of immediate local force transfer to the concrete has been provided.

Verification of the transfer of the loads to be anchored to the building component must be provided.

4.3.2. Determination of anchorage depth.

4.3.2.1. General points

The design anchorage length l_{bd} must be determined according to EN 1992-1-1, section 8.4.3. When the holes are done with diamond core drilling technique, the design values of bond stress for C20/25 shall be used for concrete of grades > C20/25.

The anchorage depths and overlap lengths must not be less than the minimum values given in annex 10. The maximum permissible anchorage depth is given in annex 6.

4.3.2.2. Calculation of the basic anchorage length $l_{b,rqd}$

The basic anchorage length $l_{b,rqd}$, for anchoring the force $A_s \cdot f_{yd}$ in the rebar assuming constant bond stress equal to f_{bd} follows from:

$l_{b,rqd} = (\phi/4) \cdot (\sigma_{sd}/f_{bd})$ where:

ϕ = diameter of the rebar

σ_{sd} = calculated stress in the rebar under the design action

f_{bd} = design value of the bond strength according to table 4 & 5 in annex 11

$f_{bd} = 2.25 \eta_1 \eta_2 f_{ctd}$ (according to EN 1992-1-1)

with $f_{ctd} = \alpha_{ct} f_{ctk,0.05} / \gamma_c$

$\alpha_{ct} = 1$ and $\gamma_c = 1.5$

η_1 coefficient relative to the quality of the bond condition and position of the rebar during concreting

$\eta_1 = 1,0$ ("good" bond conditions)

$\eta_1 = 0,7$ (all other conditions)

$\eta_2 = 1,0$ (for $\varnothing \leq 32\text{mm}$)

4.3.2.3. Calculation of the minimum anchorage length $l_{b,min}$

Anchoring rebar

In the case of anchoring rebar, the minimum anchorage length $l_{b,min}$ must be determined as follow.

For anchoring rebar in tension:

$l_{b,mi,n} = \text{Max} (0,3 l_{b,rqd}; 10 \phi; 100\text{mm})$ EN 1992-1-1 Equation 8.6

For anchoring rebar in compression:

$l_{b,mi,n} = \text{Max} (0,6 l_{b,rqd}; 10 \phi; 100\text{mm})$ EN 1992-1-1 Equation 8.7

Overlap joint

In the case of overlap joint, the minimum anchorage length $l_{0,min}$ must be determined as follow:

$l_{0,min} = \text{Max} (0,3 \cdot \alpha_6 \cdot l_{b,rqd}; 15 \phi; 200\text{mm})$ EN 1992-1-1 Equation 8.11

Where $\alpha_6 = (\rho_1/25)^{0.5} \leq 1.5$ ρ_1 is the percentage of reinforcement lapped within $0.65 l_0$ from the centre of the length considered.

4.3.2.4. Calculation of the design anchorage length l_{bd}

Anchoring rebar

In the case of anchoring rebar, the design anchorage length l_{bd} must be determined as follow:

$l_{bd} = \alpha_1 \alpha_2 \alpha_3 \alpha_4 \alpha_5 l_{b,rqd} \geq l_{b,min}$

Where $\alpha_1, \alpha_2, \alpha_3, \alpha_4, \alpha_5$ determined according to EN 1992-1-1. Table 8.2.

Overlap joint

In the case of overlap joint, the design lap length l_0 must be determined as follow:

$l_0 = \alpha_1 \alpha_2 \alpha_3 \alpha_4 \alpha_5 \alpha_6 l_{b,rqd} \geq l_{0,min}$

Where $\alpha_1, \alpha_2, \alpha_3, \alpha_4, \alpha_5, \alpha_6$ determined according to, EN 1992-1-1. Table 8.2 and 8.3

α_1	Influence of the shape of the rebar	$\alpha_1=1$ for straight rebar
α_2	Influence of the concrete cover	$0.7 \leq \alpha_2 \leq 1.0$ calculated according to EN 1992-1-1 Table 8.2
α_3	Influence of the confinement by transverse reinforcement not welded to main reinforcement	$\alpha_3=1$ because no transverse reinforcement
α_4	Influence of the confinement by welded transverse reinforcement	$\alpha_4=1$ because no transverse reinforcement
α_5	Influence of the confinement by transverse pressure	$0.7 \leq \alpha_5 \leq 1.0$
α_6	Influence of the overlapping length	$1.0 \leq \alpha_6 \leq 1.5$

Nota: Examples of calculations are published in annexes 12 and 13 for concrete C20/25. Other values can be calculated by using the above formulas.

4.3.2.5. Transverse reinforcement

The transverse reinforcement required in the zone of the rebar connection must fulfil the requirement of EN 1992-1-1, section 8.7.4.

4.3.2.6 Connection joint

In case of a connection being made between new and existing concrete where the surface layer of the existing concrete is carbonated, the layer should be removed in the area of the new reinforcing bar (with a diameter $d_s + 60\text{mm}$) prior to the installation of the new bar.

The foregoing may be neglected if building components are new and not carbonated.

4.3.2.7 Additional provisions

The concrete cover required for bonded-in rebars is shown in Annex 7, in relation to the drilling method.

Furthermore the minimum concrete cover given in EN 1992-1-1, Section 4.4.1.2 shall be observed.

4.4. Installation

The fitness for use of the rebar connection can only be assumed if the rebar is installed as follows:

- The installation of the post installed rebars shall be carried out according to the manufacturer's installation instructions
- The installation of post-installed rebars shall be done only by suitable trained installer and under supervision on site. The conditions under which an installer may be considered as suitable trained and the conditions for supervision on site are up to the Member States in which the installation is done.
- Use of the system only as supplied by the manufacturer without exchanging the components of an system;
- Checks before placing the rebar to ensure that the strength class of the concrete in which the rebar is to be placed is in the range;

- The surface of the joint between new and existing concrete should be prepared (roughing, keying, according to the envisaged intended use according to EN 1992-1-1;
- Check of concrete being well compacted, e.g. without significant voids;
- Keeping the anchorage depth as specified in the design drawings;
- Keeping of the concrete cover and spacing as specified in the design drawings;
- The drilling and cleaning of the hole and the installation shall be performed only with the equipment as specified by the manufacturer given in annexes 6 to 9. It shall be ensured that this equipment is available on site and is used;
- Positioning of the drill holes without damaging the reinforcement;
- In case of aborted drill hole: the drill hole shall be filled with mortar;
- The post installed rebar connection must not be installed in flooded holes;
- Rebar installation ensuring the specified embedment depth, that is the appropriate depth marking of the rebar not exceeding the concrete surface;

4.5. Responsibility of the manufacturer

It is the manufacturer's responsibility to ensure that the information on the specific conditions according to 1 and 2 including Annexes referred to in § 4.3. is given to those who are concerned. This information may be made by reproduction of the respective parts of the European Technical Approval. In addition all installation data shall be shown clearly on the package and/or on an enclosed instruction sheet, preferably using illustration(s).

The minimum data required are:

- drill bit diameter,
- rebar diameter,
- admissible service temperature range,
- curing time of the bonding material depending on the installation temperature,
- information on the installation procedure, including cleaning of the hole, preferably by means of an illustration,
- reference to any special installation equipment needed,
- identification of the manufacturing batch.

All data shall be presented in a clear and explicit form.

5 Recommendations concerning packaging, transport and storage.

Each cartridge of resin is marked with the identifying mark of the producer, the trade name, the charge code, storage life, curing and processing time.

The cartridges of resin shall be protected against sun radiation and shall be stored according to the manufacturer's installation instructions in dry conditions at temperatures of at least +0°C to not more than +35°C.

Mortar cartridges with expired shelf life must no longer be used.

The original French version is signed by

**Le Directeur Technique
C. BALOCHE**



Marking of the mortar cartridges :

- Identifying mark of the producer
- Trade name
- Charge code number
- Storage life
- Curing and processing time



EPOBAR Cartridge 345 ml

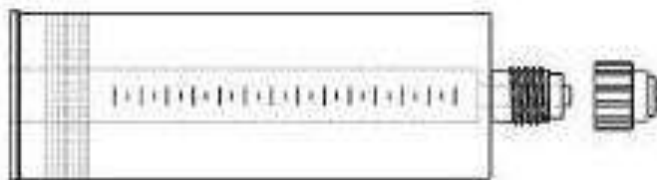

EPOBAR Cartridge 410ml

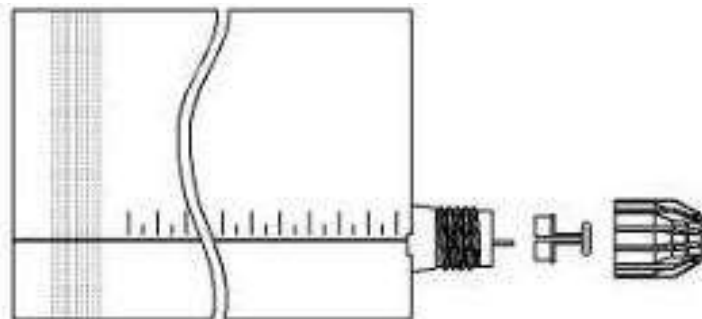

EPOBAR Cartridge 825ml

SPIT EPOBAR / EPOMAX

EPOBAR PRODUCT DESCRIPTION

Annex 1

**of the European
 Technical Approval**

ETA - 08/0201

- Metallic brush + Extension



- Mixing nozzle for cartridges 345ml - 410ml

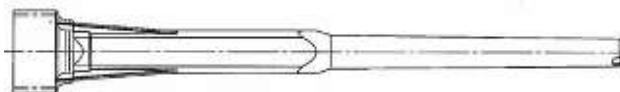

- High flow mixing nozzle for cartridges 825ml



- Reduction for mixing nozzle

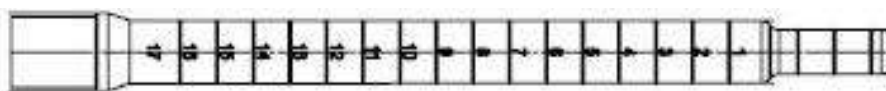

- Piston plug



Nota: The piston plug can be used for all the hole diameters by cutting it at the relevant diameter.

Plastic extension for mixing nozzle (ϕ_{ext} x l) :

- 9x196
- 9x1000
- 13x1000
- 20 x 1000

Dispensers

- Electric dispensers EGI 380 / EGI 825
- Pneumatic dispensers P380 / P825
- Manual dispensers M345 / M380

SPIT EPOBAR / EPOMAX

EPOBAR PRODUCT DESCRIPTION

Annex 2

of the European
 Technical Approval

ETA - 08/0201



Marking of the mortar cartridges:

- Identifying mark of the producer
- Trade name
- Charge code number
- Storage life
- Curing and processing time

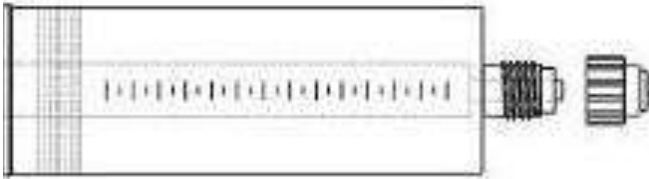

EPOMAX Cartridge 380 ml

- Metallic brush
+
Extension



- Mixing nozzle for cartridges 380ml

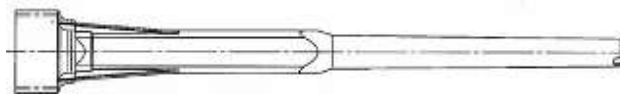

- Piston plug

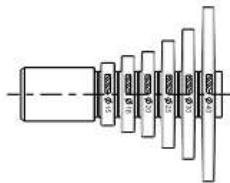

Nota: The piston plug can be used for all the hole diameters by cutting it at the relevant diameter.

Plastic extension for mixing nozzle (ϕ_{ext} x l) :

- 9x196
- 9x1000
- 13x1000
- 20 x 1000

Dispensers

- Electric dispensers EGI 380
- Pneumatic dispensers P380
- Manual dispensers M380

SPIT EPOBAR / EPOMAX

EPOMAX PRODUCT DESCRIPTION

Annex 3

**of the European
 Technical Approval**

ETA - 08/0201

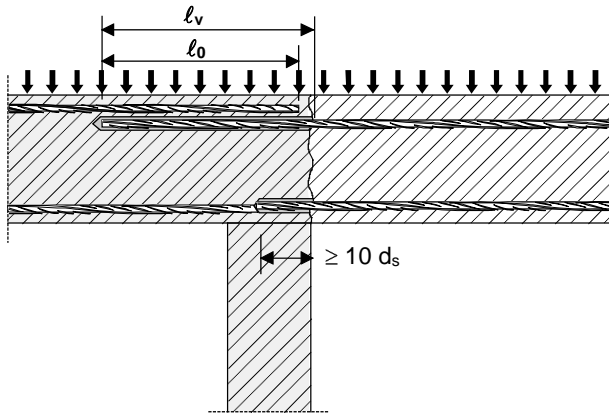

Figure 1: Overlap joint for rebar connections of slabs and beams

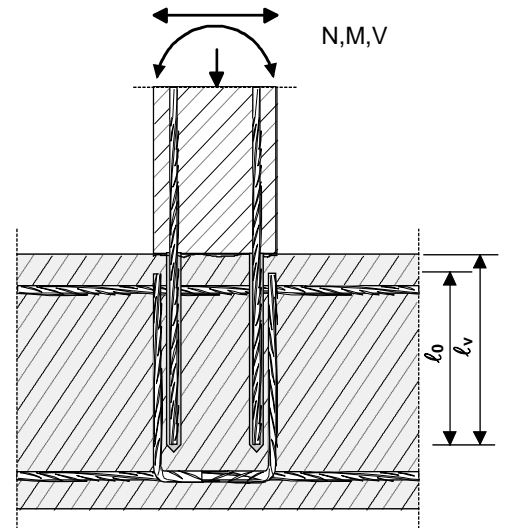

Figure 2: Overlap joint at a foundation of a column or wall where the rebars are stressed in tension

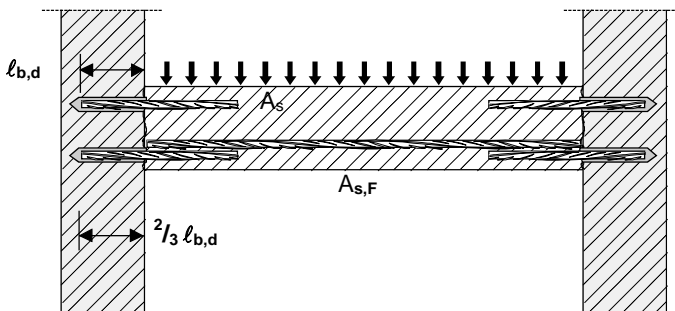

Figure 3: End anchoring of slabs or beams, designed as simply supported

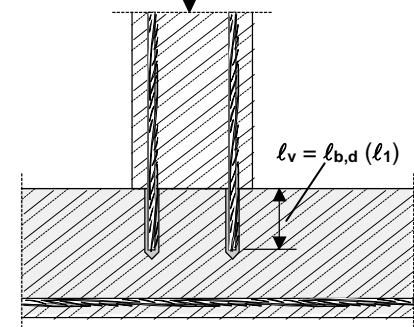

Figure 4: Rebar connection for components stressed primarily in compression. The rebars are stressed in compression

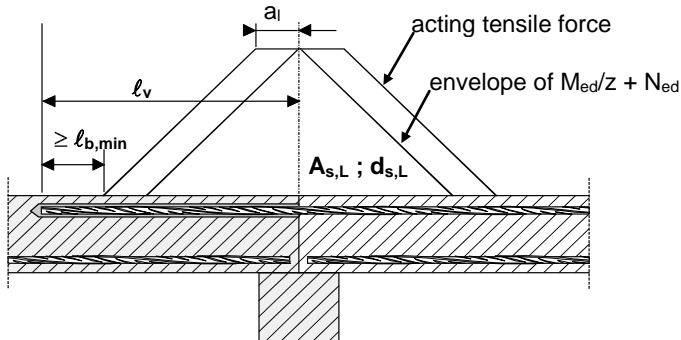

Figure 5: Anchoring of reinforcement to cover the line of acting tensile

Note to Figure 1 to 5:

In the Figures no transverse reinforcement is plotted, the transverse reinforcement as required by EC 2 shall be present.

The shear transfer between old and new concrete shall be designed

SPIT EPOBAR / EPOMAX

Intended use

Annex 4

**of the European
 Technical Approval**

ETA - 08/0201

Figure 6: Reinforcing bar “rebar” according to EC2

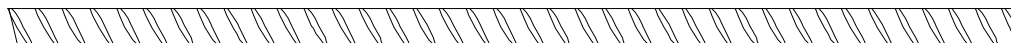

Refer to EOTA TR 023:

This Technical Report covers post-installed rebar connections in non-carbonated concrete under the assumption only that the design of post-installed rebar connections is done in accordance with EN 1992-1-1.

Covered are rebar anchoring systems consisting of bonding material and an embedded straight deformed reinforcing bar with properties according to Annex C of EN 1992-1-1; the classes B and C of the rebar are recommended.

Refer to EN 1992-1-1 Annex C Table C.1 and C.2N Properties of reinforcement:

Product form		Bars and de-coiled rods	
Class		B	C
Characteristic yield strength f_{yk} or $f_{0,2k}$ (MPa)		400 to 600	
Minimum value of $k = (f_t/f_y)_k$		$\geq 1,08$	$\geq 1,15$ < 1,35
Characteristic strain at maximum force, ϵ_{uk} (%)		$\geq 5,0$	$\geq 7,5$
Bendability		Bend / Rebend test	
Maximum deviation from nominal mass (individual bar or wire) (%)	Nominal bar size (mm) ≤ 8	$\pm 6,0$	
	> 8	$\pm 4,5$	
Bond: Minimum relative rib area, $f_{R,min}$	Nominal bar size (mm) 8 to 12	0,040	
	> 12	0,056	

SPIT EPOBAR / EPOMAX

Reinforcing bar “rebar” according to EC2

Annex 5

**of the European
 Technical Approval**

ETA - 08/0201

Drilling the hole:



Rotary hammer drilling or compressed air drilling

Diamond core drilling
 (Water in the hole is not permitted)

Rebar diameter d_{nom}	Nominal drilling diameter d_{cut}		Max Permissible anchorage depth l_v		
	Drill bit	Diamond core	EPOBAR Dispensers : M345 / M380 P380 EGI 380	EPOBAR Dispensers P825	EPOMAX Dispensers M380 P380 EGI 380
[mm]	[mm]	[mm]	[mm]	[mm]	[mm]
8	10	10	900 ⁽¹⁾	1500 ⁽²⁾	900 ⁽²⁾
10	12	12			
12	15	15			
14	18	18			
16	20	20			
20	25	25			
25	30	30			
28	35	-	1200 ⁽²⁾		
32	40	-			

(1) The temperature of the cartridge must be $\leq 40^\circ\text{C}$
 (2) The cartridge must be stored at ambient temperature (20°C)

Table 1: Drilling diameter and maximum anchorage length

Nota: The maximum outer rebar diameter over the ribs shall be:

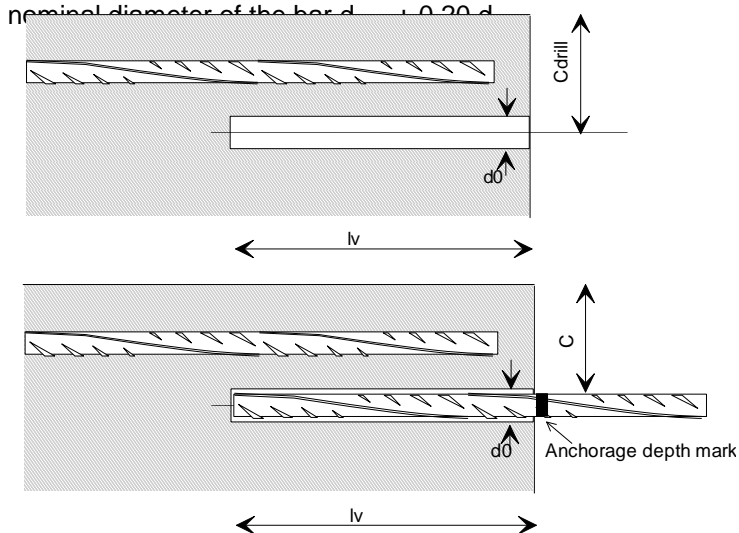

- Observe concrete coverage, c , as per setting plan.
- Drill parallel to the edge
- Put the anchorage depth mark on the rebar

SPIT EPOBAR / EPOMAX

Installation instructions of the rebars

Annex 6

**of the European
 Technical Approval**

ETA - 08/0201

Drilling the hole:

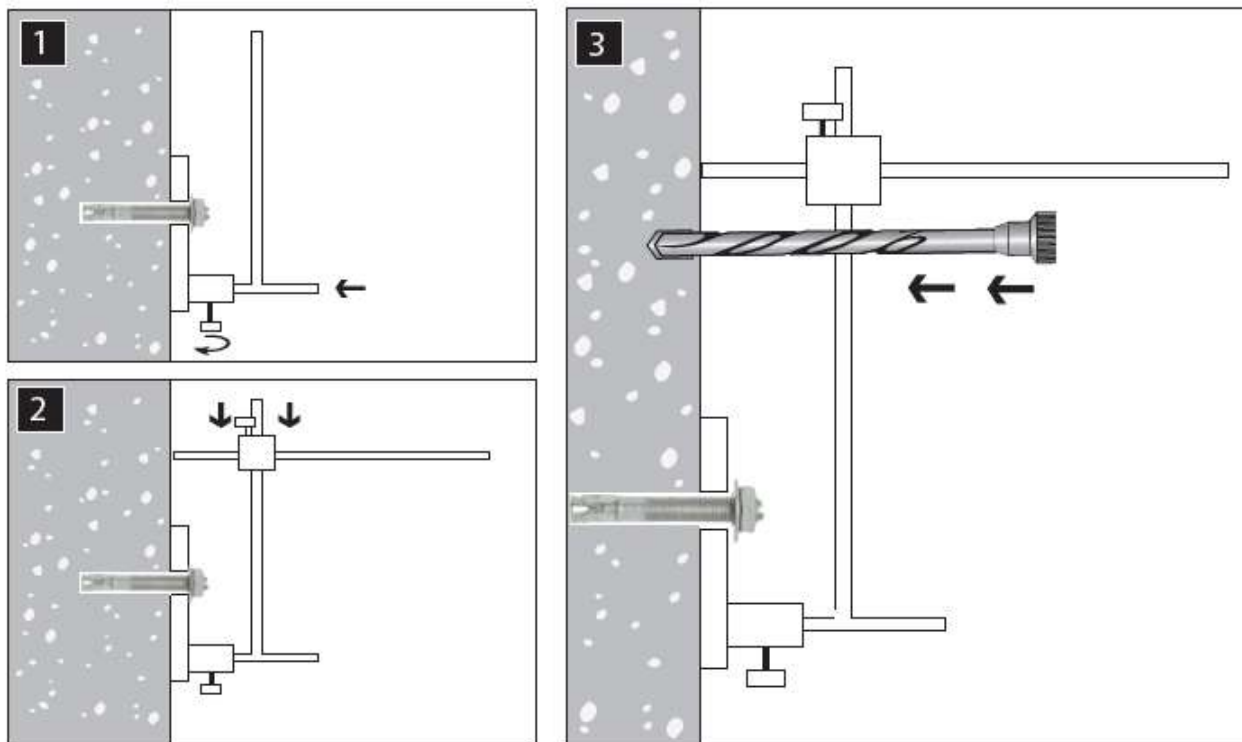

Minimum concrete cover:

$c_{min} = 30 + 0,06 l_v \geq 2d_s$ (mm) for hammer drilled holes without drilling aid

$c_{min} = 30 + 0,03 l_v \geq 2d_s$ (mm) for hammer drilled holes with drilling aid

$c_{min} = 50 + 0,08 l_v \geq 2d_s$ (mm) for compressed air drilled holes

Minimum clear spacing between two post-installed bars $a = 40 \text{ mm} \geq 4d_s$

SPIT EPOBAR / EPOMAX

Installation instructions of the rebars

Annex 7

**of the European
Technical Approval**

ETA - 08/0201

Cleaning the hole:

Hammer drilling technique

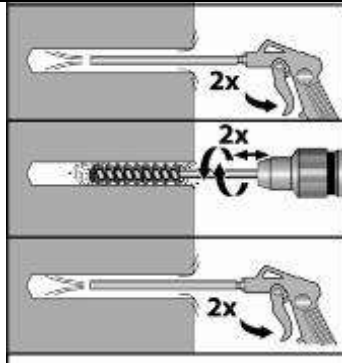

1. Insert air nozzle fitted with the relevant plastic extension to bottom of the hole and blow out at least 2 times using oil free compressed air and until no dust is evacuated.
2. Using the relevant brush and extension fitted on a drilling machine, starting from the top of the hole, move downward to the bottom of the hole (duration 5s) then move upward to the top of the hole (duration 5s). Repeat this operation.
3. Insert air nozzle fitted with the relevant plastic extension to bottom of the hole and blow out at least 2 times using oil free compressed air and until no dust is evacuated.

Diamond core drilling technique

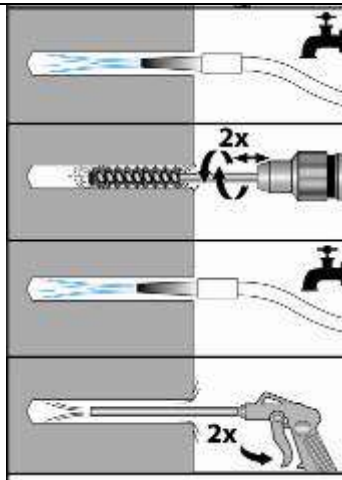

1. Clean the hole with tap water
2. Using the relevant brush and extension fitted on a drilling machine, starting from the top of the hole, move downward to the bottom of the hole (duration 5s) then move upward to the top of the hole (duration 5s). Repeat this operation.
3. Clean the hole with tap water
4. Insert air nozzle fitted with the relevant plastic extension to bottom of the hole and blow out at least 2 times using oil free compressed air and until no dust is evacuated.

Rebar diameter [mm]	Brushes	Extension for brushes	Plastic Extension for compressed air
	Diameter [mm]	[-]	[-]
8	11	Lg 325 mm	9x196 9x1000
10	13		
12	16		
14	20		
16	22		
20	26		
25	32		
28	37		
32	42		

The diameter of the round steel brush shall be checked before use. The minimum brush diameter has to be at least equal to the borehole diameter d_0 . The round steel brush shall produce natural resistance as it enters the drill hole. If this is not the case, please use a new brush or a brush with a larger diameter.

SPIT EPOBAR / EPOMAX

Installation instructions of the rebars

Annex 8

**of the European
 Technical Approval**

ETA - 08/0201

Safety precaution

The safety data sheet must be read before using the product and the safety instructions must be followed.

- Storage temperature of cartridge +0°C to +35 °C
- Cartridge temperature at time of installation: Must be $\geq +5^\circ\text{C}$
- Base material temperature at time of installation: Must be between -5°C and $+40^\circ\text{C}$
- Check the date of expiry of the cartridge

Dispensing into the hole:

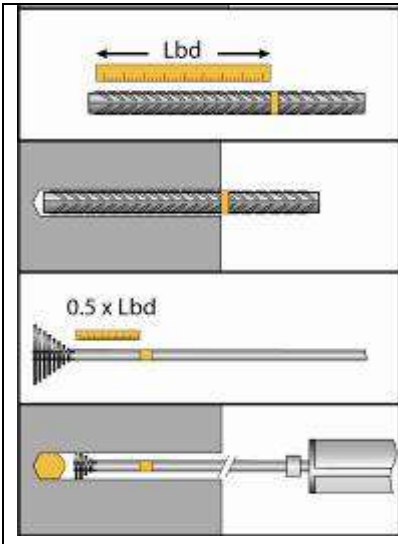

1. Put the anchorage depth mark on the rebar
2. Check the anchorage depth
3. Cut the piston plug at the relevant diameter. The volume of resin that need to be injected in the hole must be indicated on the mixing nozzle or its extension. The marking must be placed at 0.5 time the anchorage depth
4. Dispense the first part to waste of every new cartridge until an even color is achieved.
5. Insert the nozzle to the far end of the hole, and inject the resin, withdrawing the nozzle as the hole fills. Fill the hole until the mark appear.

Hole diameter [mm]	Plastic extension for mixing nozzle $\phi_{\text{ext}} \times l$	Mixing nozzle		Piston plug
	[mm]	[-]	[-]	
10 to 40	9x196 9x1000	Mixing nozzle 380 - 410		
15 to 40	13x1000	Mixing nozzle 380 - 410	+ Reduction for mixing nozzle	
35 to 40	20 x 100	High flow mixing nozzle 825		

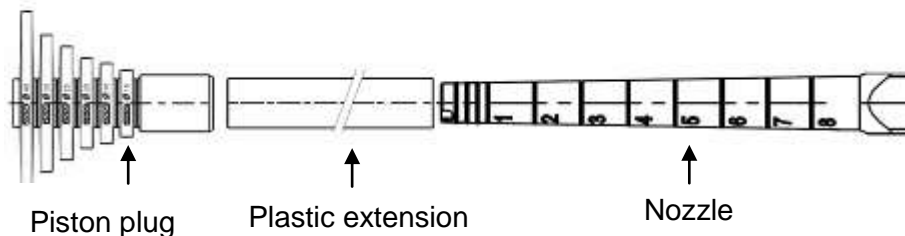

SPIT EPOBAR / EPOMAX

Installation instructions of the rebars

Annex 9

of the European
 Technical Approval

ETA - 08/0201

Inserting the rebar:

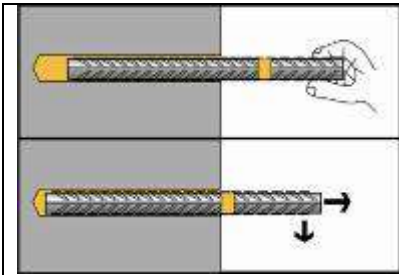

1. Immediately insert the rebar, slowly and with a slight twisting motion. Remove excess resin from around the mouth of the hole before it sets. Control the embedment depth.
2. Leave the rebar undisturbed until the cure time has elapsed.

Ambient temperature (°C)	Processing time (min)	Curing time in dry concrete (min)	Curing time in wet concrete (min)
5° à 9°C	22	250	500
10° à 19° C	11	190	380
20° à 29°C	6	110	220
30° à 39°C	3	65	130
40° C	3	50	100

Table 2: Processing and curing time for EPOBAR resin

Ambient temperature (°C)	Processing time (min)	Curing time in dry concrete (min)	Curing time in wet concrete (min)
5° à 9°C	11	210	420
10° à 19° C	6	60	120
20° à 29°C	3	40	80
30° à 39°C	1	35	70
40° C	1	30	60

Table 3: Processing and curing time for EPOMAX resin

Rebar diameter	Minimum anchorage depth		
	Anchoring rebar $l_{b,min}$	Overlap joint $l_{o,min}$	
[mm]	[mm]	[mm]	
8	113	200	Minimum anchorage length for anchoring rebar in tension: $l_{b,mi,n} = \text{Max} (0,3 l_{b,rqd}; 10 \phi; 100\text{mm})$ (EN 1992-1-1 Equation 8.6)
10	142	200	
12	170	200	
14	198	210	minimum anchorage length for overlap joint: $l_{o,mi,n} = \text{Max} (0,3 \alpha_6 \cdot l_{b,rqd}; 15 \phi; 200\text{mm})$ (EN 1992-1-1 Equation 8.11)
16	227	240	
20	284	300	Nota: The minimum anchorage depth are valid for "good bond conditions" as described in EN 1992-1-1.
25	354	375	
28	397	420	
32	454	480	

Table 4: Setting data

SPIT EPOBAR / EPOMAX	Annex 10 of the European Technical Approval ETA - 08/0201
Installation instructions of the rebars	

Ultimate bond resistance f_{bd} according to EN 1992-1-1 for hammer drilling technique and air compressed drilling									
Size	C12/15	C16/20	C20/25	C25/30	C30/37	C35/45	C40/50	C45/55	C50/60
φ 8	1.6	2.0	2.3	2.7	3.0	3.4	3.7	4.0	4.3
φ 10									
φ 12									
φ 14									
φ 16									
φ 20									
φ 25									
φ 28									
φ 30									
φ 32									

Table 4: Design values of the ultimate bond resistance according to EN 1992-1-1 for EPOBAR / EPOMAX resin

Ultimate bond resistance f_{bd} according to EN 1992-1-1 for diamond core drilling technique									
Size	C12/15	C16/20	C20/25	C25/30	C30/37	C35/45	C40/50	C45/55	C50/60
φ 8	1.6	2.0	2.3	2.3	2.3	2.3	2.3	2.3	2.3
φ 10									
φ 12									
φ 14									
φ 16									
φ 20									
φ 25									
φ 28									
φ 30									
φ 32									

Table 5: Design values of the ultimate bond resistance according to EN 1992-1-1 for EPOBAR / EPOMAX resin

Nota: The values given in tables 4 and 5 are valid for “good bond conditions” as described in EN 1992-1-1. For all other conditions multiply the values by 0.7.

SPIT EPOBAR / EPOMAX	Annex 11 of the European Technical Approval ETA - 08/0201
Design values	

SPIT EPOBAR / EPOMAX – Anchoring of Rebar HA Fe E500 – C20/25 concrete ($f_{bd}=2.3\text{Mpa}$)

Rebar \varnothing	$\alpha_1=\alpha_2=\alpha_3=\alpha_4=\alpha_5=1,0$			α_2 or $\alpha_5=0,7$ $\alpha_1 = \alpha_3 = \alpha_4 = 1,0$		
	Anchorage length l_{bd}	Tension load	Mortar volume V	Anchorage length l_{bd}	Tension load	Mortar volume V
[mm]	[mm]	[kN]	[ml]	[mm]	[kN]	[ml]
8	113 *	6.56	4	113 *	9.37	4
	170	9.83	6	150	12.39	5
	240	13.87	8	180	14.86	6
	310	17.92	11	220	18.17	7
	378	21.85	13	265	21.85	9
10	142 *	10.24	6	142 *	14.63	6
	220	15.90	9	180	18.58	7
	300	21.68	12	230	23.74	10
	380	27.46	16	280	28.90	12
	473	34.15	20	331	34.15	14
12	170 *	14.75	13	170 *	21.07	13
	260	22.54	20	220	27.25	17
	360	31.21	27	280	34.68	21
	460	39.89	35	340	42.12	26
	567	49.17	43	397	49.17	30
14	198 *	20.08	24	198 *	28.68	24
	310	31.36	37	260	37.57	31
	430	43.50	52	330	47.69	40
	540	54.63	65	390	56.36	47
	662	66.93	80	463	66.93	56
16	227 *	26.23	31	227 *	37.46	31
	350	40.46	48	300	49.55	41
	490	56.65	67	370	61.11	50
	620	71.68	84	450	74.32	61
	756	87.42	103	529	87.42	72
20	284 *	40.98	60	284 *	58.54	60
	430	62.14	91	370	76.39	78
	590	85.26	125	470	97.03	100
	740	106.94	157	560	115.61	119
	900	130.06	191	662	136.59	140
25	354 *	64.03	92	354 *	91.47	92
	490	88.51	127	470	121.29	122
	620	112.00	161	590	152.26	153
	760	137.29	197	700	180.64	181
	900	162.58	233	827	213.42	214
28	397 *	80.32	165	397 *	114.74	165
	520	105.21	216	520	150.29	216
	640	129.48	266	640	184.98	266
	770	155.79	320	770	222.55	320
	900	182.09	374	900	260.12	374
32	454 *	104.90	246	454 *	149.86	246
	560	129.48	304	560	184.98	304
	670	154.92	364	670	221.31	364
	780	180.35	423	780	257.65	423
	900	208.10	489	900	297.28	489

1) Tabulated maximum tension loads are valid for good bond conditions according to EN 1992-1-1. For all other bond conditions the values for tension loads must be multiplied by 0.7.

2) The volume V of mortar can be estimated using the equation $V = 1.2 \cdot (d_o^2 - d^2) \cdot \pi \cdot l_{bd} / 4$

* Values corresponding to the minimum anchorage length $l_{b,min}$

SPIT EPOBAR / EPOMAX

Design values

Annex 12

**of the European
 Technical Approval**

ETA - 08/0201

SPIT EPOBAR / EPOMAX – Overlap joint of Rebar HA Fe E500 – C20/25 concrete ($f_{bd}=2.3\text{Mpa}$)

Rebar \varnothing	$\alpha_1=\alpha_2=\alpha_3=\alpha_4=\alpha_5=\alpha_6=1,0$			α_2 or $\alpha_5=0,7$ $\alpha_1=\alpha_3=\alpha_4=\alpha_6=1,0$		
	Lap splice length l_0	Tension load	Mortar volume V	Lap splice length l_0	Tension load	Mortar volume V
[mm]	[mm]	[kN]	[ml]	[mm]	[kN]	[ml]
8	200 *	11.56	7	200 *	16.52	7
	240	13.87	8	210	17.34	7
	280	16.19	10	230	18.99	8
	330	19.08	11	240	19.82	8
	378	21.85	13	265	21.85	9
10	200 *	14.45	8	200 *	20.64	8
	260	18.79	11	230	23.74	10
	330	23.84	14	260	26.84	11
	400	28.90	17	290	29.93	12
	473	34.15	20	331	34.15	14
12	200 *	17.34	15	200 *	24.77	15
	290	25.15	22	240	29.73	18
	380	32.95	29	290	35.92	22
	470	40.75	36	340	42.12	26
	567	49.17	43	397	49.17	30
14	210 *	21.24	25	210 *	30.35	25
	320	32.37	39	270	39.02	33
	430	43.50	52	330	47.69	40
	540	54.63	65	390	56.36	47
	662	66.93	80	463	66.93	56
16	240 *	27.75	33	240 *	39.64	33
	360	41.62	49	310	51.20	42
	490	56.65	67	380	62.76	52
	620	71.68	84	450	74.32	61
	756	87.42	103	529	87.42	72
20	300 *	43.35	64	300 *	61.93	64
	450	65.03	95	390	80.51	83
	600	86.71	127	480	99.09	102
	750	108.38	159	570	117.68	121
	900	130.06	191	662	136.59	140
25	375 *	67.74	97	375 *	96.77	97
	500	90.32	130	480	123.87	124
	630	113.80	163	600	154.84	156
	760	137.29	197	710	183.22	184
	900	162.58	233	827	213.42	214
28	420 *	84.97	175	420 *	121.39	175
	540	109.25	224	540	156.07	224
	660	133.53	274	660	190.76	274
	780	157.81	324	780	225.44	324
	900	182.09	374	900	260.12	374
32	480 *	110.99	261	480 *	158.55	261
	580	134.11	315	580	191.58	315
	690	159.54	375	690	227.92	375
	790	182.66	429	790	260.95	429
	900	208.10	489	900	297.28	489

1) Tabulated maximum tension loads are valid for good bond conditions according to EN 1992-1-1. For all other bond conditions the values for tension loads must be multiplied by 0.7.

2) The volume V of mortar can be estimated using the equation $V = 1.2 \cdot (d_o^2 - d^2) \cdot \pi \cdot l_{0,d} / 4$

* Values corresponding to the minimum anchorage length $l_{0,min}$

SPIT EPOBAR / EPOMAX

Design values

Annex 13

**of the European
 Technical Approval**

ETA - 08/0201